

Soft-Switching Snubber Inverter

Goal

Create a converter that minimizes the additional cost required to achieve soft-switching.

Objective

Operate the inverter like a conventional hard-switched inverter with no limitations on switching timings or additional control complexity.

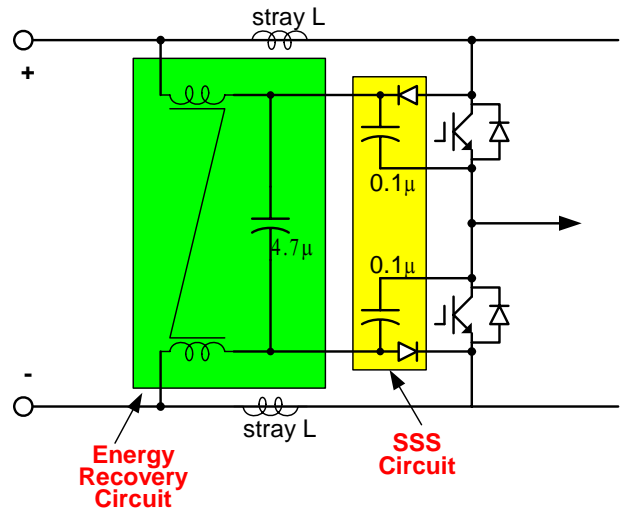

ORNL's soft-switching snubber inverter circuit diagram.

SSSI Features

- Only passive components are needed to achieve soft-switching operation
- No additional control is required to operate in a soft-switching mode
- Any traditional PWM methods can be used with the inverter
- Design has a reduced dV/dt and di/dt than hard-switched inverters
- Concept is a low-cost, reliable option for motor drives
- No need for a large planar dc bus
- Inherent circuit parasitics are incorporated into the soft-switching circuit

Project Status

- Simulation and proof of concept have been completed
- A 100 kW prototype is being assembled and tested
- Patent application has been filed and interested collaborators with industry are presently being sought

Points of Contact:

Power Electronics and Electric Machinery Research Center
Oak Ridge National Laboratory
2360 Cherahala Boulevard
Knoxville, TN 37932

Don Adams
Director
Phone: 865-946-1321
FAX: 865-946-1262
E-mail: adamsdj@ornl.gov

Laura Marlino
Technical Project Manager
Phone: 865-946-1245
FAX: 865-946-1262
E-mail: marlinold@ornl.gov

Website: peemrc.ornl.gov